

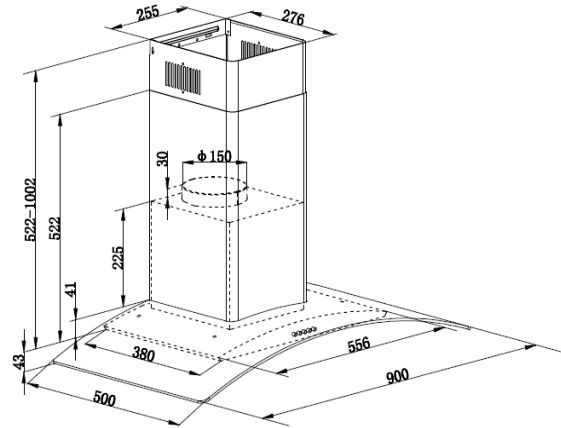

Dimension/Weight

Overall Dimensions (mm): 900(w) x 500(d) x 522-1002(h)
 Chimney Height (mm): 500+500 mm
 Gross/Net Weight: 17.5/14.7 kg



Technical Details

Style

Rangehood Type: Wall Canopy
 Rangehood Size: 90cm

Specifications

Max Airflow: 750m3 / hr
 Power Levels: 3
 Filtration: 2 x 5 Layers Black AL Filters
 Lights: 2 x 1.5W Round LED
 Motor Power: 190W
 Voltage: 240v, 50Hz
 Installation Type: Wall mounted
 Ducted or Recirculated: Both
 Come with Plug: Yes
 Warranty: 48 Months Parts & Labour

IEC 61951 Tested Air Flow		
Power Level	Air Flow (m ³ /hr)	Noise Level (dB)
1	475	51
2	553	55
3	668	57

Aesthetics

Finish: Black Painted with Tempered Glass
 Control Type: 3 Speed Electronic Button

Key Features



Black Painted with Tempered Glass

Black is on trend making this rangehood a great addition to your new or upgraded kitchen.



3 Power Levels

3 power levels to meet different cooking needs.



LED Light

This appliance looks aesthetically appealing with the black glass and LED light on the front. It will match perfectly with your Omega oven.

Customer Care

T: 09 415 6000
 W: omegaappliances.com.au
 W: omegaappliances.co.nz