

The Omega logo is rendered in a bold, lowercase, sans-serif font. The letter 'o' is distinguished by a horizontal line passing through its center. The logo is positioned in the upper left quadrant of the page, set against a light gray circular background element that partially overlaps the white page.

Instruction Manual

Bar Fridge

OBFD127B

OBFD127X

Thank you for purchasing an Omega appliance

Tailored for the modern aesthetic and lifestyle of busy people, your new Omega Appliance will make a welcome addition to the family.

Omega caters to style-savvy customers who look for balance between stunning form and clever function. This means a combination of sleek, chic, sophisticated design yet effortless functionality. And we source from the best. The best craftsmanship. The best innovation. From the best international design-houses.

All brought together under an appliance that stands for design-led balance.

Please take the time to read through the following instruction manual to familiarise yourself with the installation, operation requirements and maintenance to ensure optimum performance.

Further Information

For important information about your Omega Appliance such as warranty registration, manuals, features, and specifications please visit omegaappliances.co.nz or contact our Customer Care team on the below email or phone numbers.

Contact Us

Our customer service team is here to help you with any question or concern. Both teams are on call Monday to Friday 8.30am to 5.00pm and of course you can always send an email at your convenience.

New Zealand Contact Details

Monday to Friday 8.30am – 5.00pm

Email: customercare@monacocorp.co.nz

Phone: 09 415 6000

READ THE INSTRUCTION BOOKLET BEFORE INSTALLING AND USING THE APPLIANCE.

It is important that you retain these instructions, proof of purchase as well as other important documents about this product for future reference.

The manufacturer will not be responsible for any damage to property or to persons caused by incorrect installation or improper use of the appliance.

Due to continual product development, Omega reserves the right to alter specifications and appearances without notice.

Contents

Important Safety Warnings 4

Installation..... 5

Appliance Details..... 9

Operating Instructions..... 10

Care and Maintenance 10

Data Label and Circuit Diagram 12

Troubleshooting 13

New Zealand Product Warranty Statements of Standard Warranty Conditions 14

Disposal Information

- Most of the packaging materials are recyclable. Please dispose of these materials through your local recycling depot or by placing them into appropriate collection containers.
- If you wish to discard this product, please contact your local authorities and ask for the correct method of disposal.

Important Safety Warnings

Read the assembly instruction section and safety precautions of this booklet carefully before removing the contents of this carton.

1. This appliance is not intended for use by persons (including children) with reduced physical, sensory or mental capabilities, or lack of experience or knowledge, unless they have been given supervision or instruction concerning the use of the appliance by a person responsible for their safety. Young children should be supervised to ensure that they do not play with the appliance.
2. In certain circumstances electrical appliances may be a safety hazard.
3. Do not place heavy objects on this appliance.
4. The appliance is not intended to be operated by means of an external timer or separate remote-control system.
5. Electrical connection must be made as per local wiring rules and regulations. Do not disconnect the appliance with wet hands and do not disconnect the power cord with extreme force. Do not coil the cord while in use but keep any excess cord to the back of the appliance. Take care that the power socket is accessible.
6. The appliance should be unplugged when not in use and before any maintenance is carried out on the appliance.
7. If the supply cord is damaged, it must be replaced by the manufacturer, its Authorised Service Centre or a similarly qualified person in order to avoid a hazard.
8. **WARNING:** Ensure that the ventilation openings, in the appliance enclosure or in the built-in structure, are not obstructed. Follow the installation requirements in this manual. Avoid prolonged exposure to direct sunlight.
9. **WARNING:** Do not use mechanical devices or other means to accelerate the defrosting process, other than those recommended by the manufacturer.
10. **WARNING:** Keep ventilation openings, in the appliance enclosure or in the built-in structure, clear of obstruction.
11. **WARNING:** Do not use mechanical devices or other means to accelerate the defrosting process, other than those recommended by the manufacturer.
12. **WARNING:** Do not damage the refrigerant circuit.
13. **WARNING:** Do not use electrical appliances inside the food storage compartments of the appliance.
14. **WARNING:** When positioning the appliance, ensure the supply cord is not trapped or damaged.
15. **WARNING:** Do not locate multiple portable socket-outlets or portable power supplies at the rear of the appliance.
16. Do not store explosive substances such as aerosol cans with flammable propellant in this appliance. Do not modify this appliance.
17. This appliance must be correctly installed by a suitably qualified person, strictly in accordance with the manufacturer's instructions. Please see the specific section of this booklet that refers to installation.
18. When disposing of this appliance, please do so according to local regulations as it contains flammable gas and refrigerant.
19. Do not place hot items on plastic areas of appliance. Do not refreeze food once defrosted. Store pre-packed frozen food in accordance to the manufacturer's instructions. Take care when freezing liquids as sealed containers can explode under pressure.
20. The refrigerant isobutene (R600a) contained within the refrigerant circuit of the appliance is a natural gas with a high level of environmental compatibility, which is nevertheless flammable.
21. During transportation, installation and servicing of the appliance ensure that none of the components of the refrigerant circuit are damaged.
22. Avoid open flames and sources of ignition.
23. Thoroughly ventilate the room in which the appliance is situated.



DO NOT OPERATE THIS APPLIANCE BEFORE READING THE INSTRUCTION DO NOT BOOKLET PLACE ARTICLES ON OR AGAINST THIS APPLIANCE DO NOT STORE CHEMICALS OR FLAMMABLE MATERIALS OR SPRAY AEROSOLS NEAR THIS APPLIANCE

This appliance is intended to be used in household and similar applications such as:

Staff kitchen areas in shops, offices and other working environments; Farm houses and by clients in hotels, motels and other residential type environments; Bed and breakfast type environments; Catering and similar non-retail applications.



WARNING: Risk of fire / flammable materials

Installation

Unpacking the Appliance

Remove the external & internal packaging.

When unpacking the appliance please check for any damage. If damage is found, do not connect to the power source and contact the Authorised Service Provider.

Before connecting the appliance to the power source, let it stand upright for approximately 4 hours. This will reduce the possibility of a malfunction in the cooling system from handling during transportation. Remove any protective film from the outer surface.

Clean the interior surface with lukewarm water using a soft cloth.

Installing the Refrigerator

This appliance is designed to be free standing only, and should not be recessed or built-in.

Place your appliance on a solid, level floor that is strong enough to support the appliance when it is fully loaded. Use the adjustable feet at the bottom of the appliance to compensate for any unevenness of the floor.

Allow at least 50 mm of space around the back and sides of the appliance, which allows the proper air circulation, and at least 100 mm above the unit.

Locate the appliance away from direct sunlight and sources of heat (stove, heater, radiator, etc.). Direct sunlight may affect the acrylic coating and heat sources may increase electrical consumption. Extreme cold ambient temperatures may also cause the appliance not to perform properly. Avoid locating the appliance in moist areas.

Plug the appliance into an exclusive, properly installed-grounded wall outlet. Do not under any circumstances cut or remove the third (ground) prong from the power cord. Any questions concerning power and/or grounding should be directed toward a certified electrician or an Authorised Service Centre. After plugging the appliance into a wall outlet (220-240V 50Hz), let the appliance at least 2 hours before placing food in the freezer.

Reverse Door

Tool required: Philips screwdriver, flat bladed screwdriver, hexagonal spanner.

- Ensure the unit is unplugged and empty.
- To take the door off, it is necessary to tilt the unit backwards. Rest the unit on something solid so that it will not slip during the door reversing process.
- All parts removed must be saved to do the reinstallation of the door.
- Do not lay the unit flat as this may damage the coolant system.
- Two persons required for this installation.

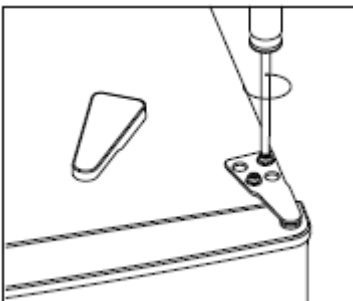

1. Remove hinge cover and then unscrew hinge bracket.

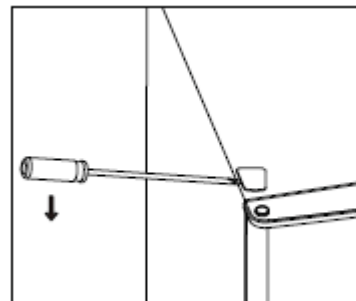

2. Remove the top left screw cover.

Installation

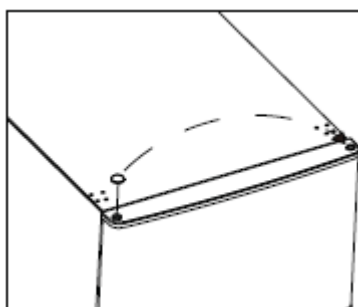

3. Move the core cover from left side to right side. And then lift the upper door and place it on a padded surface to prevent it from scratching.

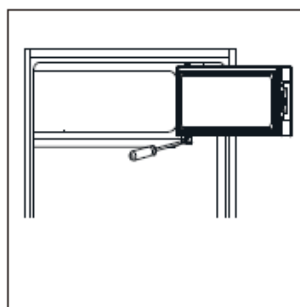

4. Unscrew bottom hinge of freezer door. Then remove the door and place it on a soft pad to avoid scratch.

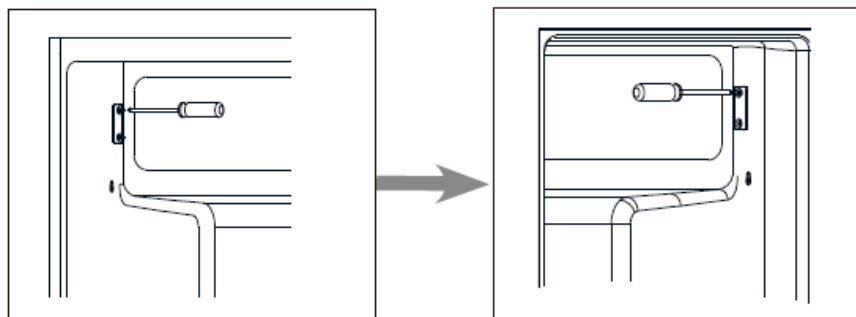

5. Move door holder from left side to right side.

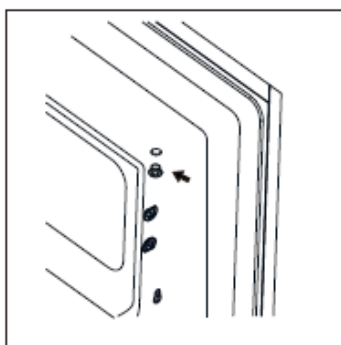

6. Move hinge hole cover from left side to right side.

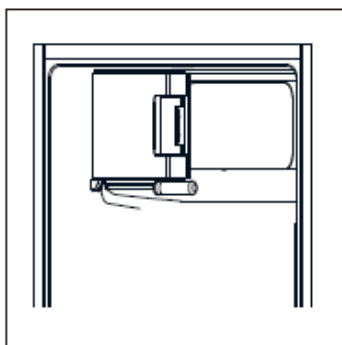

7. Rotate freezer door and place hinge side at left side. And then fix the door by holder.

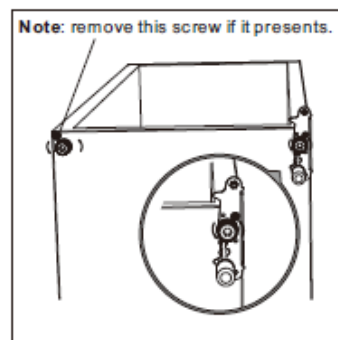

8. Unscrew bottom hinge. Then remove the adjustable feet from both sides.

Installation

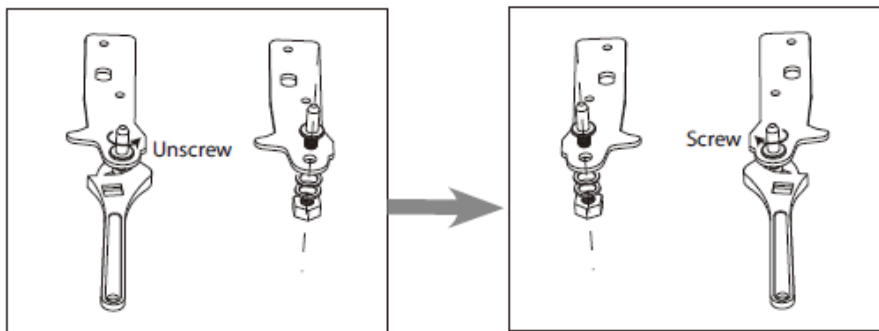

9. Unscrew and remove the bottom hinge pin, turn the bracket over and replace it.

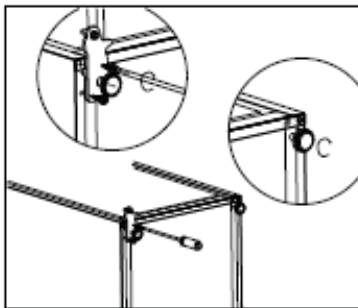

10. Refit the bracket fitting the bottom hinge pin. Replace both adjustable feet.

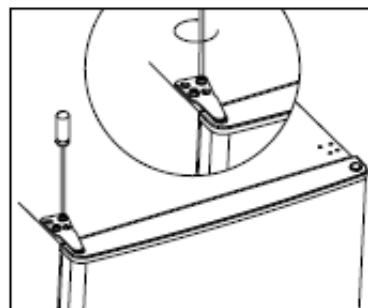

11. Place the door back on. Ensure the door is aligned horizontally and vertically so that the seals are closed on all sides before finally tightening the top hinge.

Insert the hinge bracket and screw it to the top of the unit. Use a spanner to tighten if it necessary.

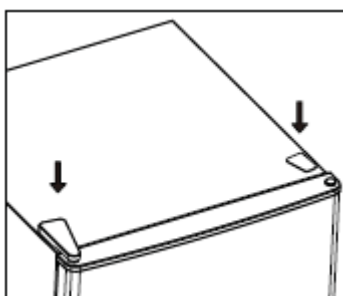

12. Put the hinge cover and the screw cover back.

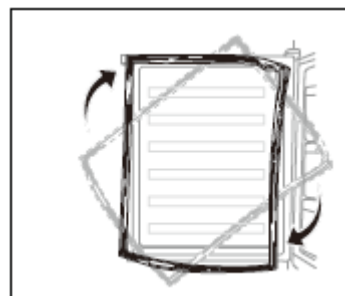

12. Detach the fridge and the freezer door gaskets and then attach them after rotating.

Installation

Levelling the unit

To do this adjust the two levelling feet at front of the unit. If the unit is not level, the doors and magnetic seal alignment will not be covered properly.

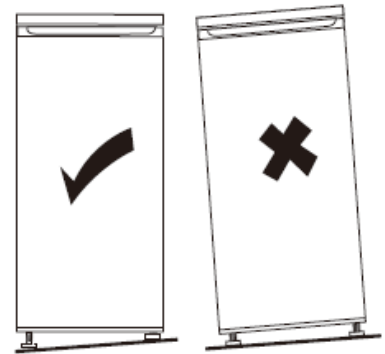

Positioning

Install this appliance at a location where the ambient temperature corresponds to the climate class indicated on the rating plate of the appliance.

Climate class	Ambient temperature
SN	+10°C to +32°C
N	+16°C to +32°C
ST	+16°C to +38°C
T	+16°C to +43°C

Location

The appliance should be installed well away from sources of heat such as radiators, boilers, direct sunlight etc. Ensure that air can circulate freely around the back of the cabinet. To ensure best performance, if the appliance is positioned below an overhanging wall unit, the minimum distance between the top of the cabinet and the wall unit must be at least 100 mm. Ideally, however, the appliance should not be positioned below overhanging wall units. Accurate leveling is ensured by one or more adjustable feet at the base of the cabinet.



Warning! It must be possible to disconnect the appliance from the mains power supply; the plug must therefore be easily accessible after installation.

Electrical connection

Before plugging in, ensure that the voltage and frequency shown on the rating plate correspond to your domestic power supply. The appliance must be earthed. The power supply cable plug is provided with a contact for this purpose. If the domestic power supply socket is not earthed, connect the appliance to a separate earth in compliance with current regulations, consulting a qualified electrician.

The manufacturer declines all responsibility if the above safety precautions are not observed.

Appliance Details

ELECTRICAL DETAILS:

Rated Voltage: 220-240 Vac 50 Hz.
Supply Connection: 10 A domestic socket.
Max Rated Inputs: See data label on unit.

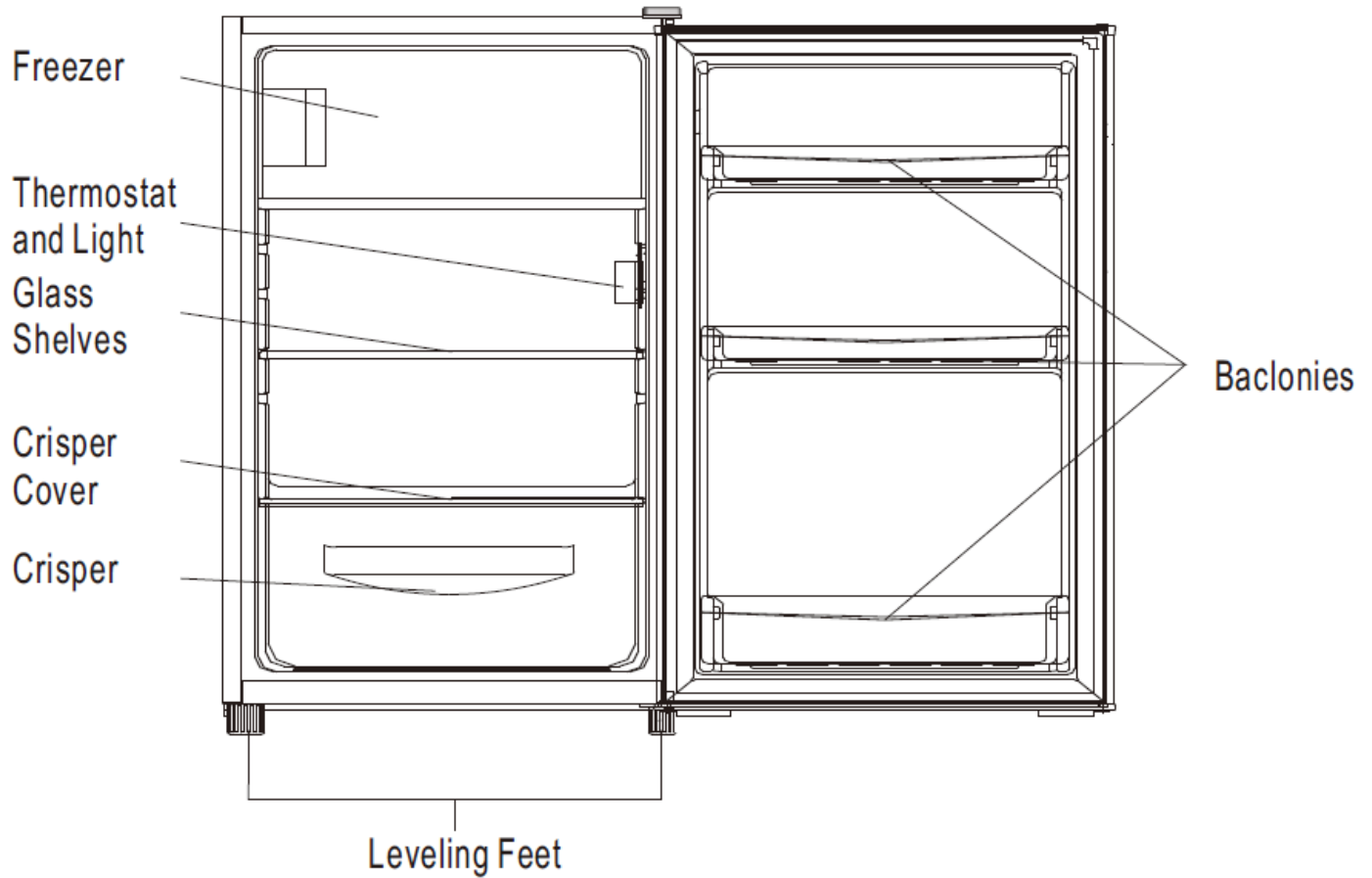

Operating Instructions

First use

Cleaning the interior

Before using the appliance for the first time, wash the interior and all internal accessories with lukewarm water and some neutral soap so as to remove the typical smell of a brand new product, then dry thoroughly.

Important! Do not use detergents or abrasive powders, as these will damage the finish.

Temperature Setting

- Plug on your appliance. The internal temperature is controlled by a thermostat. There are 8 settings. 1 is warmest setting and 7 is coldest setting and 0 is off.
- The appliance may not operate at the correct temperature if it is in a particularly hot or if you open the door often.

Freezing fresh food

- The freezer compartment is suitable for freezing fresh food and storing frozen and deep-frozen food for a long time.
- Place the fresh food to be frozen in the freezer compartment.
- The maximum amount of food that can be frozen in 24 hours is specified on the rating plate.
- The freezing process lasts 24 hours: during this period do not add other food to be frozen.

Storing frozen food

When first starting-up or after a period out of use, before putting the product in the compartment let the appliance run at least 2 hours on the higher settings.

Important! In the event of accidental defrosting, for example the power has been off for longer than the value shown in the technical characteristics chart under “rising time”, the defrosted food must be consumed quickly or cooked immediately and then re-frozen (after cooked).

Thawing

Deep-frozen or frozen food, prior to be used, can be thawed in the fridge compartment or at room temperature, depending on the time available for this operation.

Small pieces may even be cooked still frozen, directly from the freezer. In this case, cooking will take longer.

Ice-cube

This appliance may be equipped with one or more ice-cube to produce ice.

Accessories

Movable shelves

The walls of the refrigerator are equipped with a series of runners so that the shelves can be positioned as desired.

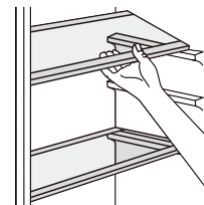

Positioning the door shelf

To permit storage of food packages of various sizes, the door shelf can be placed at different heights. To make these adjustments proceed as follows: gradually pull the shelf in the direction of the arrows until it comes free, then reposition as required.

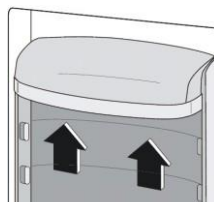

Care and Maintenance

CLEANING THE APPLIANCE

Upon installation of your new appliance, it is recommended that it be cleaned thoroughly, and cleaned once a month after that.

To clean the appliance, first turn the thermostat to 0, turn off the power, unplug from the power socket and remove all food and shelving.

Wash the inside with a damp warm cloth containing a water and baking soda solution. The solution should be about 2 tablespoons of baking soda to a quart of water.

Wash the shelving with a mild detergent solution.

Be sure to keep the door gasket (seal) clean to keep the unit running efficiently.

The outside of the appliance should be cleaned with mild detergent and warm water. Dry the interior and exterior with a soft cloth.

It is recommended that the unit be cleaned each time it is defrosted to help keep the unit odour free and running efficiently.

Do not use oils, abrasive cleaners, petroleum products, acids or alkaline detergents, as they can damage the appliance.

IMPORTANT: If your appliance appears not to be operating correctly, turn off the appliance at the switch and then contact the Service Department.

DO NOT ATTEMPT TO REPAIR THE APPLIANCE YOURSELF.

REPLACING THE LAMP

The lamp must be replaced from the qualified service center and qualified technician.

MOVING THE APPLIANCE

Remove all the food.

Securely tape down all loose items inside the appliance. Tape the doors shut.

Be sure the appliance stays in the upright position during transportation.

ENERGY SAVING TIPS

The appliance should be located in the coolest area of the room, away from heat producing appliances or heating ducts, and out of the direct sunlight.

Let hot foods cool to room temperature before placing in the appliance. Overloading the appliance forces the compressor to run longer. Foods that cool or freeze too slowly may lose quality, or spoil.

Be sure to wrap foods properly, and wipe containers dry before placing them in the appliance. This cuts down on frost build-up inside the freezer and bad odours.

The freezer compartment should not be lined with aluminium foil, wax paper, or paper towels. Liners interfere with cold air circulation, making the freezer less efficient.

Organize and label food to reduce door openings and extended searches. Remove as many items as needed at one time, and close the door as soon as possible.

When adding fresh food, try to add it to the bottom of the freezer, surrounded by food that is already frozen. After adding fresh food to the freezer, allow 24 hours for it to be fully frozen before adding any more fresh food.

omega

OBFD127B

Refrigerator

Total Volume: 127L

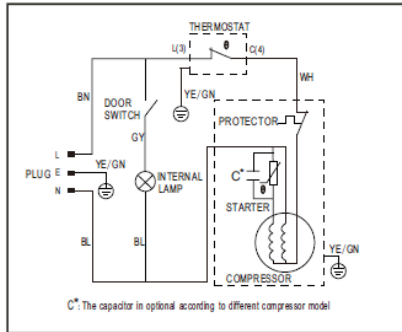

220 - 240V ~50Hz
 Rated Current:
 Energy Consumption:
 Climate Class:
 Refrigerant:
 Insulation Blow Gas:

0.75A
 155kWh/year
 T
 R600a (21g)
 Cyclopentane



Caution: Risk of Fire/
 Flammable material



Made in China

omega

OBFD127X

Refrigerator

Total Volume: 127L

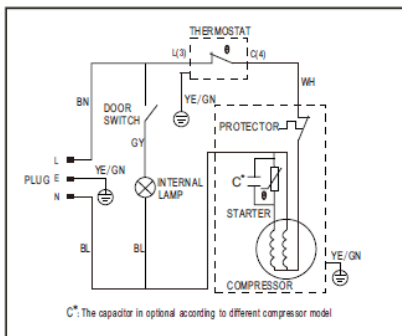

220 - 240V ~50Hz
 Rated Current:
 Energy Consumption:
 Climate Class:
 Refrigerant:
 Insulation Blow Gas:

0.75A
 155kWh/year
 T
 R600a (21g)
 Cyclopentane



Caution: Risk of Fire/
 Flammable material



Made in China

Troubleshooting

PROBLEM	POSSIBLE CAUSE
Appliance does not operate.	Not plugged in. The circuit breaker tripped or a blown fuse.
Compressor turns on and off frequently.	The room temperature is hotter than normal. A large amount of food has been added to the freezer. The door is open too often, or not fully closed. The temperature control is not set correctly. The door gasket does not seal properly. The appliance does not have the correct clearances. The appliance has recently been disconnected for a period of time. Four hours are required for the appliance to cool down completely.
Temperature inside the appliance is too warm.	Temperature control is set too warm. Turn the control to a cooler setting and allow several hours for the temperature to stabilize. Door is kept open too long or opened too frequently. Open the door less. The door is not closed completely. The door gasket does not seal properly. A large amount of warm or hot food might have been stored recently. Wait until the appliance has had a chance to reach its selected temperature. The appliance has recently been disconnected for a period of time. Four hours are required for the appliance to cool down completely.
Temperature inside the appliance is too cold.	Temperature control is set too cold. Turn the control to a warmer setting and allow several hours for the temperature to stabilize.
Popping or cracking sound when compressor comes on.	Metal parts undergo expansion and contraction, as in hot water pipes. This is normal. Sound will level off or disappear as freezer continues to run.
Bubbling or gurgling sound, like water boiling.	Refrigerant (used to cool appliance) is circulating throughout the system. This is normal.
Vibrations.	Check to assure that the appliance is level. Floor is uneven or weak. Appliance rocks on the floor when it is moved slightly. Be sure floor can adequately support appliance. Level the appliance by adjusting the adjustable feet. The appliance is touching the wall. Re-level the appliance and move it from the wall. See "Installation Instructions".
Moisture forms on inside freezer walls.	Weather is hot and humid, which increases internal rate of frost build-up. This is normal. Door is slightly open. Door is kept open too long, or is opened too frequently. Open the door less often. The door is not sealed properly.
Moisture forms on outside of appliance. The door will not close properly.	Door is slightly open, causing cold air from inside the freezer to meet warm moist air from outside. The appliance is not level. The gasket is dirty.

New Zealand Product Warranty Statements of Standard Warranty Conditions

Nothing herein contained shall be construed in any way as excluding or limiting your rights under the Consumer Guarantee Act 1993.

OUR WARRANTY

This product is also covered by the manufacturer's warranty set out in this document (Our Warranty). Our Warranty is for a period of forty eight (48) months from the date of purchase.

This is in addition to (and does not exclude, restrict or modify) any rights or remedies to which you may already be entitled to under the New Zealand Consumer Guarantee act 1993 relating to this product.

Our warranty (which is subject to the conditions below) covers rectification free of charge of any fault arising from defective materials or components or faulty workmanship.

The product will be repaired or replaced at the option of Omega.

Our warranty is subject to the following conditions:

1. That the purchaser contacts Omega prior to any product repair.
2. That the purchaser carefully follows all instructions provided with the product and complies with all relevant electrical & plumbing regulations when installing the product.
3. That the purchaser carefully follows the instructions provided in the owner's handbook relating to the proper use and care of the product and does not use the product for any purpose other than the DOMESTIC use for which it has been designed.

WHAT IS COVERED: By Our Warranty

During the warranty period, Omega or its authorised Service Centre will, at no extra charge, if your appliance is readily accessible without the need of special equipment and subject to the terms and conditions of this warranty, repair or replace any parts which it considers defective.

WHAT IS NOT COVERED: By Our Warranty

- 1 Products installed damaged or incomplete or not in compliance with the relevant electrical & plumbing regulations in their State.
- 2 Normal wear and tear e.g. cleaning, light globes, filters etc.
- 3 Failure resulting from power surges and electrical storms.
- 4 Insect or vermin infestation.
- 5 Unauthorised repairs or use of non-genuine Omega parts.
- 6 Any failure caused by the product not being used in accordance with the instruction and the installation manual provided with the product.
- 7 Misuse or abuse, including failure to properly maintain or service.
- 8 The clearing of blockages in pumps and hoses.
- 9 Damage which occurs during delivery or installation.
- 10 Claims to product surface coating due to liquid or solid spill-overs, accidental damage or damage caused from cleaning products not recommended by Omega.

HOW TO CLAIM YOUR WARRANTY

If you are contacting Omega regarding any warranty claims and spare parts inquiries, please make sure you have the following information on hand:

1. **Product Name/Model Number**
2. **Serial Number/s**
3. **Purchase Date (as per invoice or proof of purchase)**
4. **Purchased From**

www.omegaappliances.co.nz

Omega is division of Monaco Corporation Limited

(Member Shriro Australia PTY LTD)

Phone: (09) 415 6000

Email: customercare@monacocorp.co.nz



omega

omegaappliances.co.nz